

CTR2131-2*** 1250Mbps PX20 ONU Transceiver

REV1.0

Feature

- ◆ 1250Mb/s TX/RX Data Rate
- ◆ 1310nm FP-LD Burst Mode Transmitter
- ◆ 1490nm PIN/TIA Continuous Mode Receiver
- ◆ SFF 2X10 Package
- ◆ Metal enclosure for lower EMI
- ◆ Single Fiber Full Duplex Operation
- ◆ Pigtail optical interface with Optional Connector
- ◆ International Class 1 laser safety certified, Compliant with IEC60825-1
- ◆ Single +3.3V power supply, and low power dissipation
- ◆ Operating temperature range: 0°C~+70 °C and -40°C~+85 °C optional
- ◆ RoHS Compliance



Application

- ◆ Gigabit Ethernet Passive Optical Networks (GE-PON) – ONU side
- ◆ Gigabit Ethernet Point-to-Point Bi-directional Transmission
- ◆ Fiber to the Home, Curb, Office(FTTX)

Standard

- ◆ IEEE 802.3ah 1000BASE-PX20
- ◆ Small Form Factor Transceiver Multi-Source Agreement July 5,2000

General

The optical transceiver is designed for Gigabit Ethernet Passive Optical Network(GEPON) 20km transmission system. The module incorporates 1310nm burst mode transmitter and 1490nm continuous mode receiver. The transmitter section uses a 1310nm FP-LD and a integrated burst mode laser driver which is designed to be class 1 eye safe under any single fault. The laser driver includes APC and temperature compensation circuit, which are used for keeping the launch optical power and extinction ratio constant over temperature and aging. The receiver section uses an integrated continuous 1490nm InGaAs PIN photodiode. The module has the function that indicates receiver signal-detected status (active high). An integrated WDM coupler can separate 1310nm output light and 1490nm input light.

Specification

Absolute Maximum Ratings

Parameter	Symbol	Min.	Max.	Unit
Storage temperature	Ts	-40	85	°C
Power Supply Voltage	Vcc	-0.5	+4	V
Operation Relative Humidity	RHo	5	85	%
Storage Relative Humidity	RHs	5	85	%
Input Optical Power	Pmax		+4	dBm

Recommended Operation conditions

Parameter	Symb	Min.	Typ.	Max.	Unit
Operating Case Temperature(0°C~+70 °C)	To	0		70	°C
Operating Case Temperature(-40°C~+85°C)	To	-40		85	°C
Power Supply Voltage	Vcc	3.13		3.47	V
Power Supply Current	Icc		180	250	mA
Data Rate			1.25 ± 100ppm		Gbps

Electrical/Optical Characteristics

Parameter	Symbol	Min	Typ	Max	Unit	Ref
Transmitter						
Electrical Characteristics						
Data Rate			1.25		Gbps	
Input differential impedance	Z _{in}	90	100	110	Ω	
Differential input voltage	V _{in,pp}	200		1600	mV	LVPECL
Transmit Disable Voltage	VD	2.0		3.3	V	LVTTTL
Transmit Enable Voltage	VEN	0		0.8	V	LVTTTL
TX Disable Assert Time	TD _{off}			10	us	
TX Disable Negate Time	TD _{on}			1	ms	
TX Fault Assert Voltage	V _{fault_A}	2.0		3.3	V	LVTTTL
TX Fault Dessert Voltage	V _{fault_D}	0		0.8	V	LVTTTL
Burst Control Voltage-High	V _{burst_High}	2.0		3.3	V	LVTTTL
Burst Control Voltage-Low	V _{burst_Low}	0		0.8	V	LVTTTL
Burst Enable Delay	T _{on}			30	ns	
Burst Disable Delay	T _{off}			30	ns	
Burst Enable Duration	T _{en_DUR}	600			ns	
Burst Disable Duration	T _{dis_DUR}	100			ns	
Optical Characteristics						
Transmitter Type		1310nm Burst Mode FP-LD				
Output Opt. Power	P _{out}	-1		+4	dBm	NOTE 1
Po @TX Disable Asserted	P _{off}			-45	dBm	
Optical Wavelength	λ _c	1260	1310	1350	nm	NOTE 2
Spectral Width	Δλ			2.5	nm	
Extinction Ratio	ER	9			dB	
Optical Rise/Fall Time	tr/tf		150	260	ps	NOTE 3
RIN	RIN			-120	Db/Hz	NOTE 4
Total Jitter	TJ			0.4	UI	NOTE 5
Optical Return Loss				15	dB	
Transmitter Reflectance				-6	dB	
Dispersion Penalty	TDP			1.8	dB	
Eye Diagram	Complies with IEEE802.3ah 2004 eye masks when filtered					

Receiver						
Electrical Characteristics						
Data Rate			1.25			Gbps
Differential Output Voltage	V _{out,pp}	600	800	1000	mV	LVPECL
SD=HIGH	VOH	2.0		3.3	V	LVTTTL
SD=LOW	VOL	0		0.8	V	LVTTTL

SD Assert Time	T_SD_A			100	us	
SD Dessert Time	T_SD_D			100	us	
Optical Characteristics						
Receiver Type		1490nm Continuous Mode PIN/TIA				
Wavelength	λ_c	1480	1490	1500	nm	
Sensitivity	P _{sen}	-	-	-26	dBm	NOTE6
Overload Input Optical Power	POL	-3			dBm	
Maximum Input Optical Power	P _{in(max)}			+4	dBm	
Return Loss	RL	12				
SD Assert	P _a			-27	dBm	
SD DeAssert	P _d	-42			dBm	
LOS Hysteresis	Phy	0.5	3	5	dB	
Cross Talk	CT			-40	dB	

Note 1. The optical power is launched into SMF.

Note 2. 1000BASE-PX20-D and 1000BASE-PX20-U transmitter spectral limits

Note 3. Optical transition time is the time interval required for the rising or falling edge of an optical pulse to transition between the 20% and 80% amplitudes relative to the logical 1 and 0 levels

Note 4. RIN is the laser noise, integrated over a specified bandwidth, measured relative to average optical power with 12dB return loss.

Note 5. Measured with TJ-free data input signal, the TJ should be the sum of input total jitter in actual application.

Note 6. Measured with a PRBS 2⁷-1 test pattern, @1.25Gb/s, ER=10dB, BER<10⁻¹²

Pin Definitions

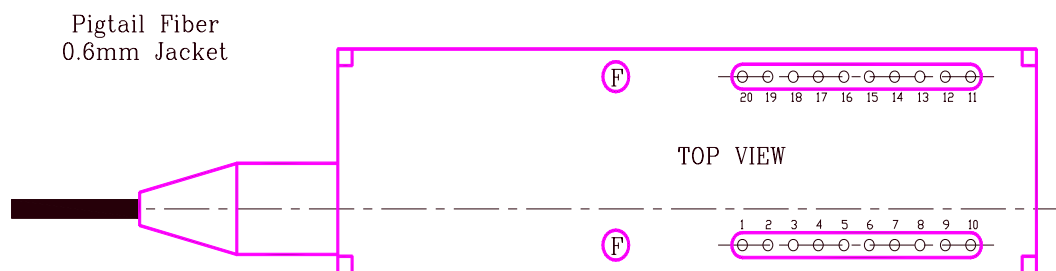

Pin Num.	Name	Function	Notes
1	NC	Not Connect	
2	VEER	Receiver Ground	
3	VEER	Receiver Ground	
4	NC	Not Connect	
5	NC	Not Connect	
6	VEER	Receiver Ground	
7	VCCR	Receiver Power	3.3V ± 5%
8	SD	Signal Detect	LVTTL

9	RD-	Receiver Output-	AC Coupled Internally
10	RD+	Receiver Output+	AC Coupled Internally
11	VCCT	Transmitter Power	3.3V ± 5%
12	VEET	Transmitter Ground	
13	TXDIS	Transmitter Disable	LVTTL, H:Disable;L:Enable;NC:Disable
14	TD+	Transmitter Input+	AC Coupled Internally
15	TD-	Transmitter Input-	AC Coupled Internally
16	VEET	Transmitter Ground	
17	TX_Burst	Burst Mode Transmit on/off Control	High:Burst mode enable. Low: burst mode disable.Optional
18	TX_Fail	Transmitter Failure Indicator	High:Failure occurs,Low:Normal
19	NC	Not Connect	
20	NC	Not Connect	

1) SD is an open collector/drain output, which should be pulled up with a 4.7k-10KΩ resistor on the host board. When high, output indicates normal operation. Low indicates signal not detect.

2) RD-/+ : These are the differential receiver outputs. They are AC coupled 100 Ω differential lines which should be terminated with 100 Ω (differential) at the user SERDES. The AC coupling is done inside the module and is thus not required on the host board. The voltage swing on these lines will be between 600 and 1000 mV differential when properly terminated.

3) TX disable is an input that is used to shut down the transmitter optical output. It is pulled up within the module with a 4.7 – 10 KΩ resistor. Its states are:

Low (0 – 0.8V): Transmitter on

(>0.8, < 2.0V): Undefined

High (2.0 – 3.3V): Transmitter Disabled

Open: Transmitter Disable

4) TD-/+ : These are the differential transmitter inputs. They are AC-coupled, differential lines with 100Ω differential termination inside the module. The AC coupling is done inside the module and is thus not required on the host board. The inputs will accept differential swings of 200 – 1600 mV.

5) TX Fault is an open collector/drain output, which should be pulled up with a 4.7K – 10KΩ resistor on the host board. Pull up voltage between 2.0V and VCCT+0.3V. When high, output indicates a laser fault of some kind. Low indicates normal operation. In the low state, the output will be pulled to < 0.8V.

6) VCCR and VCCT are the receiver and transmitter power supplies. They are defined as 3.3V ±5% . Maximum supply current is 250 mA.

Block Diagram

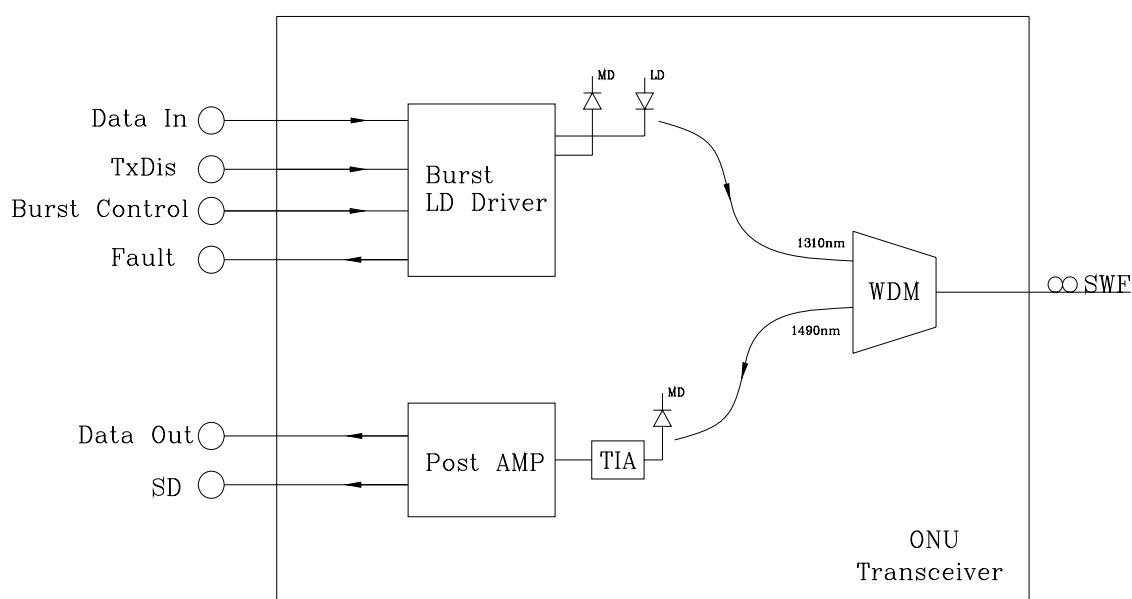

Typical application Circuit

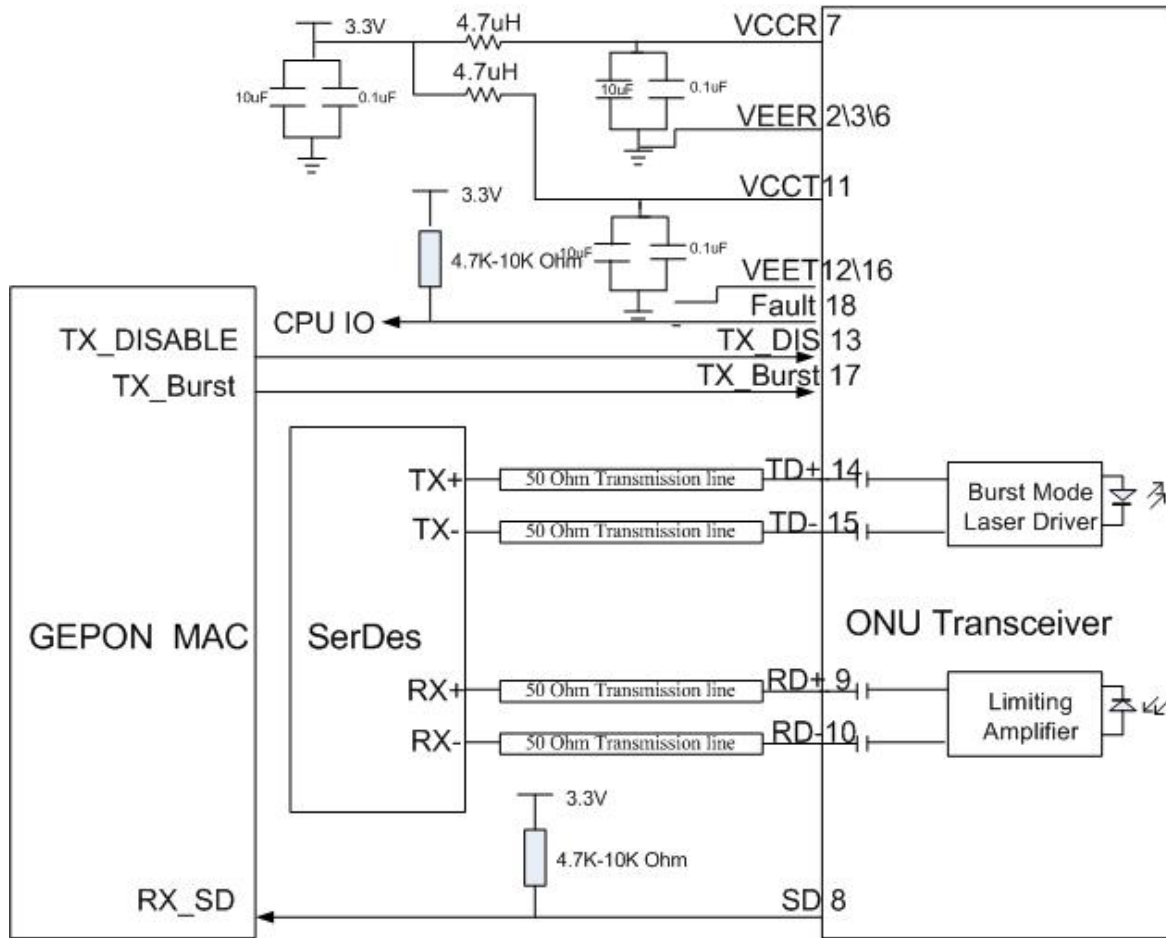

Package Outline

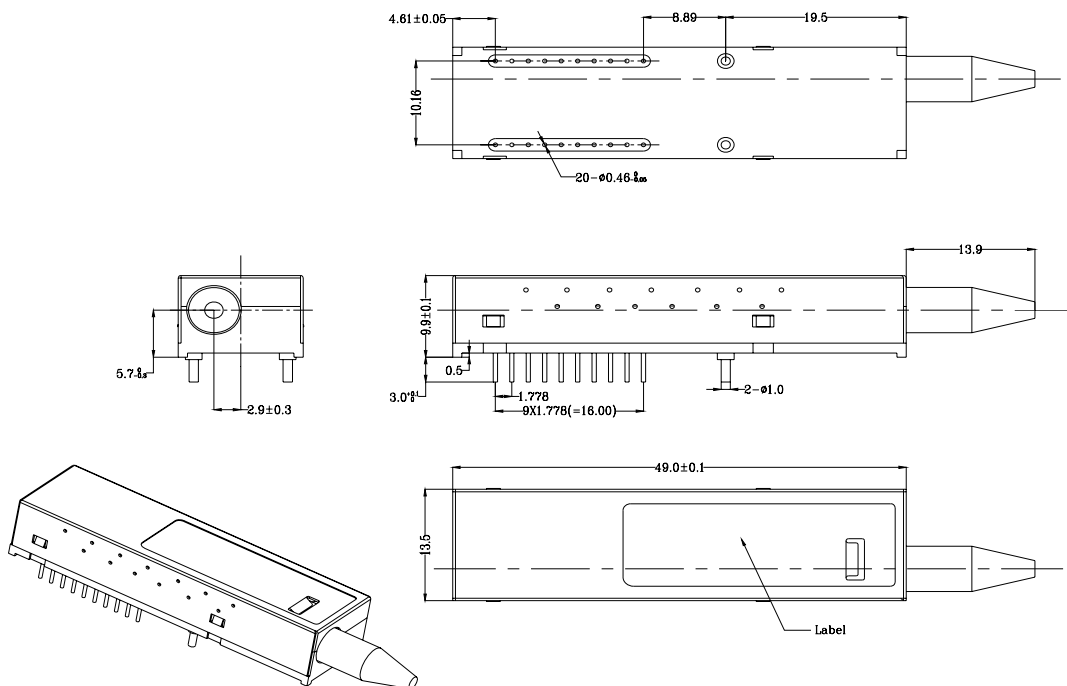

Ordering information

Part No	Burst Option(X)	Temp Option(Y)	Package Option(Z)
CTR2131-2XYZ	H:High Enable L:Low Enable	C:Comercial (0℃~+70℃) I:Industrial(-40℃~+85℃)	U:SC/UPC Pig tail A:SC/APC Pig tail

Part No	Specifications					
	Pack	Rate	Tx/Rx WaveLength	Po (dBm)	Sen (dBm)	Application
CTR2131-1***	SFF 2X10	1.25Gbps	1310nm FP/1490nm PIN	-1~4	<-25	PX10 ONU
CTR2132-1***	SFF 2X10	1.25Gbps	1490nm DFB/1310nm PIN	-3~2	<-26	PX10 OLT
CTR2131-2***	SFF 2X10	1.25Gbps	1310nm FP/1490nm PIN	-1~4	<-26	PX20 ONU
CTR2131-3***	SFF 2X10	1.25Gbps	1310nm DFB/1490nm PIN	-1~4	<-26	PX20 ONU
CTR2132-2***	SFF 2X10	1.25Gbps	1490nm DFB/1310nm APD	2~7	<-30	PX20 OLT
CTR2111-1***	SFF 2X5	1.25Gbps	1310nm FP/1490nm PIN	-1~4	<-25	PX10 ONU
CTR2112-1***	SFF 2X5	1.25Gbps	1490nm DFB/1310nm PIN	-3~2	<-26	PX10 OLT
CTR2111-2***	SFF 2X5	1.25Gbps	1310nm FP/1490nm PIN	-1~4	<-26	PX20 ONU
CTR2111-3***	SFF 2X5	1.25Gbps	1310nm DFB/1490nm PIN	-1~4	<-26	PX20 ONU
CTR2112-2***	SFF 2X5	1.25Gbps	1490nm DFB/1310nm APD	2~7	<-30	PX20 OLT

Revision History

REV 1.0 2008.03.27 Initial Release.