

CTR1115** transceiver

REV1.0

Features

- ◆ Up to 155Mbps data links
- ◆ Uncooled FP laser and PIN photo-detector
- ◆ Multi-source package with Duplex LC connector
- ◆ Metal enclosure for lower EMI
- ◆ Hot-pluggable SFP footprint
- ◆ Built-in DDM function compatible with SFF-8472 (No DDM optional)
- ◆ International Class 1 laser safety certified, Compliant with IEC60825-1
- ◆ Single +3.3V power supply, and low power dissipation <600mW typical
- ◆ Operation temperature range: -10°C~+75 °C; or -40°C~+85 °C
- ◆ RoHS Compliance

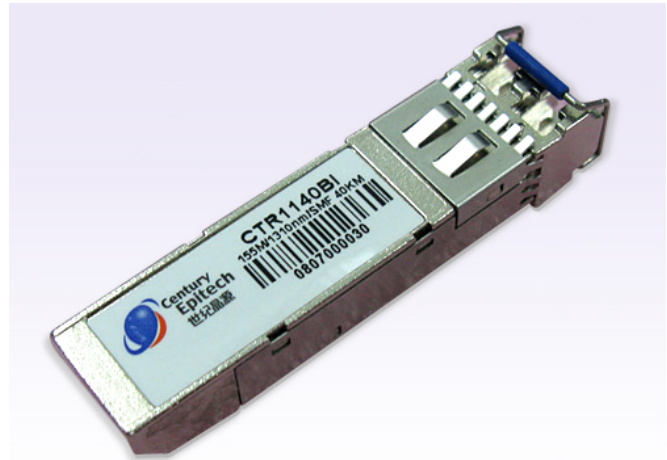

Applications

- ◆ ATM
- ◆ SONET/SDH
- ◆ Ethernet
- ◆ Other optical link

Standard

- ◆ Compliant with SFP MSA (INF-8074i)
- ◆ Compliant with SFF-8472 v9.3
- ◆ Compliant with IEEE802.3ah
- ◆ ITU-T G.957 S-1.1

Performance Specifications

Absolute Maximum Ratings

Parameter	Symbol	Min.	Max.	Unit
Storage temperature(Non-operating)	Ts	-40	85	°C
Power Supply Voltage	Vcc	-0.5	+4	V
Operating Relative Humidity	-	5	85	%
Input Optical Power	Pmax	-	+3	dBm

Recommended Operation conditions

Parameter	Symbol	Min.	Typ.	Max.	Unit
Operating Case Temperature(CTR11***C)	Tc	0	-	70	°C
Operating Case Temperature(CTR11***E)		-10	-	75	°C
Operating Case Temperature(CTR11***I)		-40	-	85	-
Power Supply Voltage	Vcc	3.13	3.3	3.47	V
Power Supply Current	Icc	-	170	300	mA
Data Rate	-	-	155	-	Mbps

Electrical/Optical Characteristics

Parameter	Symbol	Min	Typ	Max	Unit	Ref
Transmitter						
Electrical Characteristics						
Input differential impedance	Z _{in}	90	100	110	Ω	
Single ended data input swing	V _{in,pp}	150	-	800	mV	
Transmit Disable Voltage	V _D	V _{cc} -1.3	-	V _{cc}	V	
Transmit Enable Voltage	V _{EN}	V _{ee}	-	V _{ee} +0.8	V	
TX_FAULT High Voltage	V _{Hout}	V _{cc} -1.3	-	V _{cc}	V	
TX_FAULT Low Voltage	V _{Lout}	V _{ee}	-	V _{ee} +0.8	V	
TX Disable Assert Time	T _{off}	-	-	10	us	
TX Disable Negate Time	T _{on}	-	-	1	ms	
Time to initialize, include reset of TX_FAULT	T _{init}	-	-	300	ms	
TX_FAULT Assert Time	T _{fault}	-	-	100	us	
TX_DISABLE To Start Reset	T _{reset}	10	-	-	us	
Optical Characteristics						
Output Opt. Power	P _o	-15	-	-8	dBm	
P _o @TX Disable Asserted	P _{odis}	-	-	-45	dBm	Note 1
Optical Wavelength	λ _c	1261	1310	1360	nm	
Spectral Width	Δλ	-	-	7.7	nm	
Extinction Ratio	Ex	10	-	-	dB	
Dispersion Penalty	-	-	-	2	dB	
Eye Diagram	Complies with IEEE802.3z eye masks when filtered					
Receiver						
Electrical Characteristics						
Single Ended Data Output Swing	V _{out,pp}	200	-	500	mV	
LOS High Voltage	V _{Hout}	V _{cc} -0.5	-	V _{cc}	V	
LOS Low Voltage	V _{Lout}	V _{ee}	-	V _{ee} +0.5	V	
LOS Assert Time	T _{los_on}	-	-	100	us	
LOS De-Assert Time	T _{los_off}	-	-	100	us	
Optical Characteristics						
Receiver Sensitivity	S	-	-37	-34	dBm	
Overload Input Optical Power	P _{in}	-8	-	-	dBm	
Optical Center Wavelength	λ _c	1260	-	1600	nm	
LOS De-Assert	-	-	-	-37	dBm	
LOS Assert	-	-52	-	-	dBm	
LOS Hysteresis	-	0.5	3	5	dB	Note 3

Note 1. The optical power is launched into SMF.

Note 2. Measured with a PRBS $2^{23} - 1$ test pattern, @1.25Gb/s, EX=10dB, BER<10⁻¹²

Note 3. The LOS Hysteresis to minimize “chatter” on the output line. In principle, Hysteresis alone does not guarantee chatter-free operation

Digital Diagnostic Memory Map

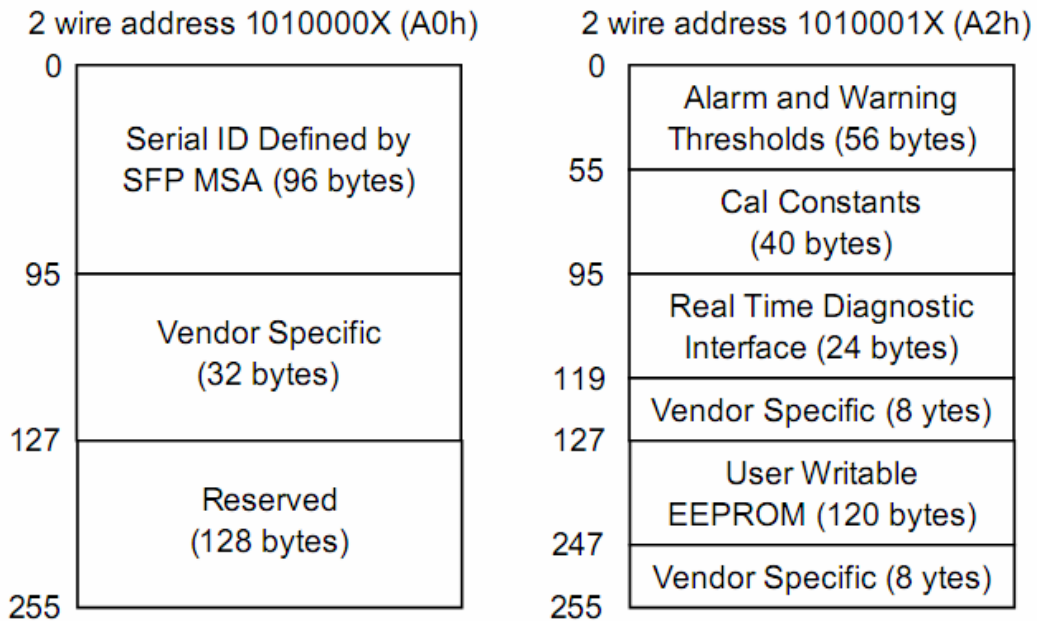

EEPROM Serial ID Memory Contents

Accessing Serial ID Memory uses the 2 wire address 1010000X(A0). Memory Contents of Serial ID are following:

Data Address	Size(Bytes)	Name of Field	Contents(Hex)	Description
BASE ID FIELDS				
0	1	Identifier	03	SFP
1	1	Ext. Identifier	04	SFP function is defined by serial ID only
2	1	Connector	07	LC Connector
3-10	8	Transceiver		Transceiver Codes
11	1	Encoding	03	NRZ
12	1	BR, Nominal		Data rate
13	1	Reserved	00	
14	1	Length (9μm) km		Transceiver transmit distance
15	1	Length (9μm) 100m		
16	1	Length (50μm) 10m		
17	1	Length(62.5μm)10m		
18	1	Length (Copper)	00	Not compliant
19	1	Reserved	00	
20-35	16	Vendor name	43 65 6e 74 75 72 79 32 45 70 69 74 65 63 68	“Century Epitech”(ASCII)
36	1	Reserved	00	
37-39	3	Vendor OUI		
40-55	16	Vendor PN		Transceiver part number
56-59	4	Vendor rev	49 46 48 32	1.0
60-61	2	Wavelength		Transceiver wavelength
62	1	Reserved	00	
63	1	CC_BASE	Check Sum (Variable)	Check code for Base ID Fields

EXTENDED ID FIELDS				
64-65	2	Options	00 1A	TX_DISABLE, TX_FAULT and Loss of Signal implemented.
66	1	BR,max	00	
67	1	BR,min	00	
68-83	16	Vendor SN	30 38 30 33 30 30 30 30 30 31	Serial Number of transceiver (ASCII). For example "0803000001".
84-91	8	Date code	30 38 30 34 30 35 20 20	Manufactory date code. For example "080405".
92	1	Diagnostic		Digital diagnostic monitoring
93	1	Enhanced Options		Optional Alarm/Warning flags implemented for all monitored quantities, Optional Soft TX_FAULT monitoring implemented, Optional Soft RX_LOS monitoring implemented.
94	1	SFF_8472 Compliance		Includes functionality described in Rev9.3 SFF-8472.
95	1	CC_EXT	Check Sum (Variable)	Check sum for Extended ID Field.
VENDOR SPECIFIC ID FIELDS				
96-127	32	Vendor Specific	Read only	Depends on customer information
128-255	128	Reserved	Read only	Filled by zero

Pin Definitions or Descriptions

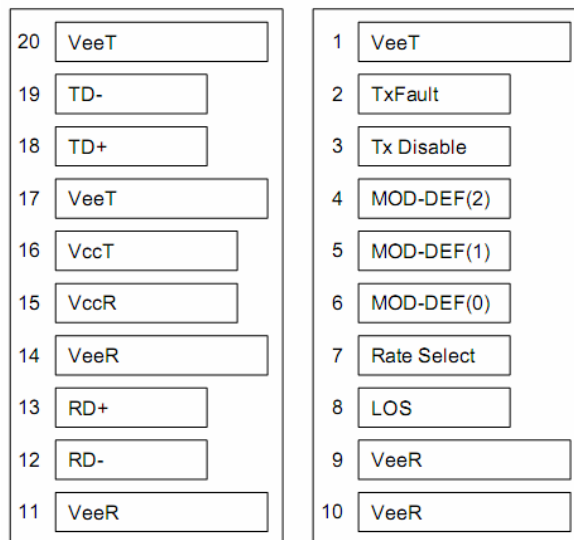

Top of Board

Bottom of Board

Pin Num.	Name	Function	Plug Seq.	Notes
1	VeeT	Transmitter Ground	1	
2	TX Fault	Transmitter Fault Indication	3	Note 1
3	TX Disable	Transmitter Disable	3	Note 2, Module disables on high or open
4	MOD-DEF2	Module Definition 2	3	Note 3, 2 wire serial ID interface

5	MOD-DEF1	Module Definition 1	3	Note 3, 2 wire serial ID interface
6	MOD-DEF0	Module Definition 0	3	Note 3, Grounded in Module
7	Rate Select	Not Connected	3	
8	LOS	Loss of Signal	3	Note 4
9	VeeR	Receiver Ground	1	Note 5
10	VeeR	Receiver Ground	1	Note 5
11	VeeR	Receiver Ground	1	Note 5
12	RD-	Inv. Received Data Out	3	Note 6
13	RD+	Received Data Out	3	Note 6
14	VeeR	Receiver Ground	1	Note 6
15	VccR	Receiver Power	2	Note 7
16	VccT	Transmitter Power	2	Note 7
17	VeeT	Transmitter Ground	1	Note 5
18	TD+	Transmit Data In	3	Note 8
19	TD-	Inv. Transmit Data In	3	Note 8
20	VeeT	Transmitter Ground	1	Note 5

Plug Seq.: Pin engagement sequence during hot plugging.

- 1) TX Fault is an open collector/drain output, which should be pulled up with a 4.7K – 10K Ω resistor on the host board. Pull up voltage between 2.0V and VccT, R+0.3V. When high, output indicates a laser fault of some kind. Low indicates normal operation. In the low state, the output will be pulled to < 0.8V.
- 2) TX disable is an input that is used to shut down the transmitter optical output. It is pulled up within the module with a 4.7 – 10 K Ω resistor. Its states are:
 - Low (0 – 0.8V): Transmitter on
 - (>0.8, < 2.0V): Undefined
 - High (2.0 – 3.465V): Transmitter Disabled
 - Open: Transmitter Disable
- 3) Mod-Def 0,1,2. These are the module definition pins. They should be pulled up with a 4.7K – 10K Ω resistor on the host board. The pull-up voltage shall be VccT or VccR (see Section IV for further details).
 - Mod-Def 0 is grounded by the module to indicate that the module is present
 - Mod-Def 1 is the clock line of two wire serial interface for serial ID
 - Mod-Def 2 is the data line of two wire serial interface for serial ID
- 4) LOS (Loss of Signal) is an open collector/drain output, which should be pulled up with a 4.7K – 10K Ω resistor. Pull up voltage between 2.0V and VccT, R+0.3V. When high, this output indicates the received optical power is below the worst-case receiver sensitivity (as defined by the standard in use). Low indicates normal operation. In the low state, the output will be pulled to < 0.8V.
- 5) VeeR and VeeT may be internally connected within the SFP module.
- 6) RD-/+: These are the differential receiver outputs. They are AC coupled 100 Ω differential lines which should be terminated with 100 Ω (differential) at the user SERDES. The AC coupling is done inside the module and is thus not required on the host board. The voltage swing on these lines will be between 370 and 2000 mV differential (185 – 1000 mV single ended) when properly terminated.
- 7) VccR and VccT are the receiver and transmitter power supplies. They are defined as 3.3V \pm 5% at the SFP connector pin. Maximum supply current is 300 mA. Recommended host board power supply filtering is shown below. Inductors with DC resistance of less than 1 Ω should be used in order to maintain the required voltage at the SFP input pin with 3.3V supply voltage. When the recommended supply filtering network is used, hot plugging of the SFP transceiver module will result in an inrush current of no more than 30 mA greater than the steady state value. VccR and VccT may be internally connected within the SFP transceiver module.
- 8) TD-/+: These are the differential transmitter inputs. They are AC-coupled, differential lines with 100 Ω differential termination inside the module. The AC coupling is done inside the module and is thus not required on the host board. The inputs will accept differential swings of 500 – 2400 mV (250 – 1200 mV single-ended), though it is recommended that values between 500 and 1200 mV differential (250 – 600 mV single-ended) be used for best EMI performance.

Package information

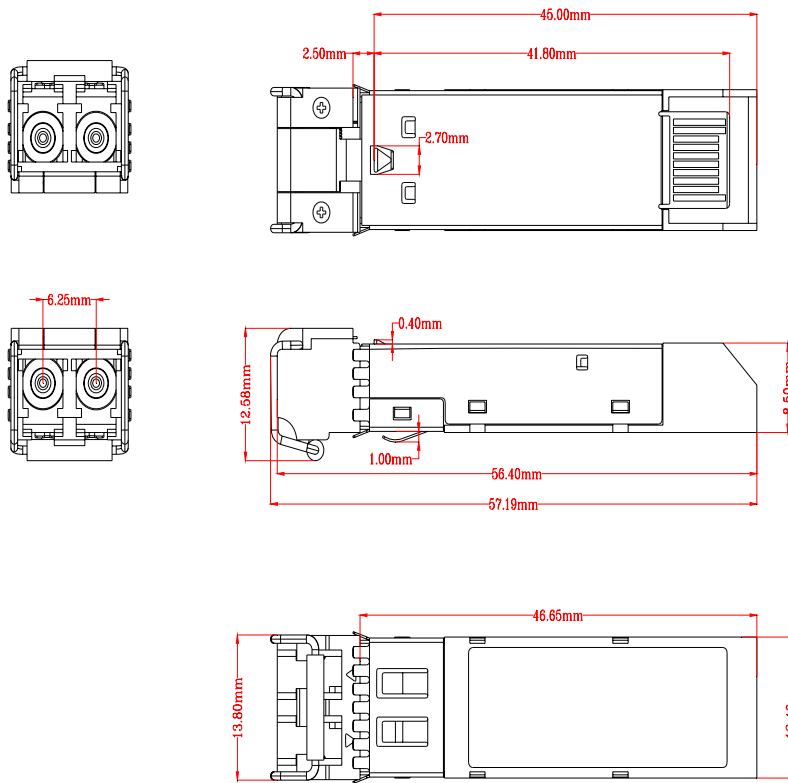

Recommended Circuit



NOTE: 4.7K ohms<RES<10K ohms

Ordering information

Part No	Specifications								Others
	Pack age	Rate (Mbps)	Tx (nm)	Po (dBm)	Rx	Sen (dBm)	Temp (°C)	Reach (Km)	
CTR1115NC	SFP	155	1310 FP	-15~-8	PIN	<-34	0~70	15	RoHS,Note1
CTR1115BC	SFP	155	1310 FP	-15~-8	PIN	<-34	0~70	15	
CTR1115DC	SFP	155	1310 FP	-15~-8	PIN	<-34	0~70	15	
CTR1115NE	SFP	155	1310 FP	-15~-8	PIN	<-34	-10~75	15	
CTR1115BE	SFP	155	1310 FP	-15~-8	PIN	<-34	-10~75	15	
CTR1115DE	SFP	155	1310 FP	-15~-8	PIN	<-34	-10~75	15	
CTR1115NI	SFP	155	1310 FP	-15~-8	PIN	<-34	-40~85	15	
CTR1115BI	SFP	155	1310 FP	-15~-8	PIN	<-34	-40~85	15	
CTR1115DI	SFP	155	1310 FP	-15~-8	PIN	<-34	-40~85	15	

Note1:
N: No DDM
B:DDM,User Writable EEPROM
D:DDM,User Writable EEPROM with password